

Componentes   Components   Composants		
A	 x4 + x4 + x4 + x4 + x4 + x4	pg.2
B C	 x7 + máx. 900 x6	pg.4
D	 x1 + 813 x1	pg.5
E	 x2 + 853 x2	pg.6
F	 x4 + x4	pg.7

Estantes y cajonera no incluidos | Shelves and drawers not included | Étagères et tiroirs non inclus

A

1

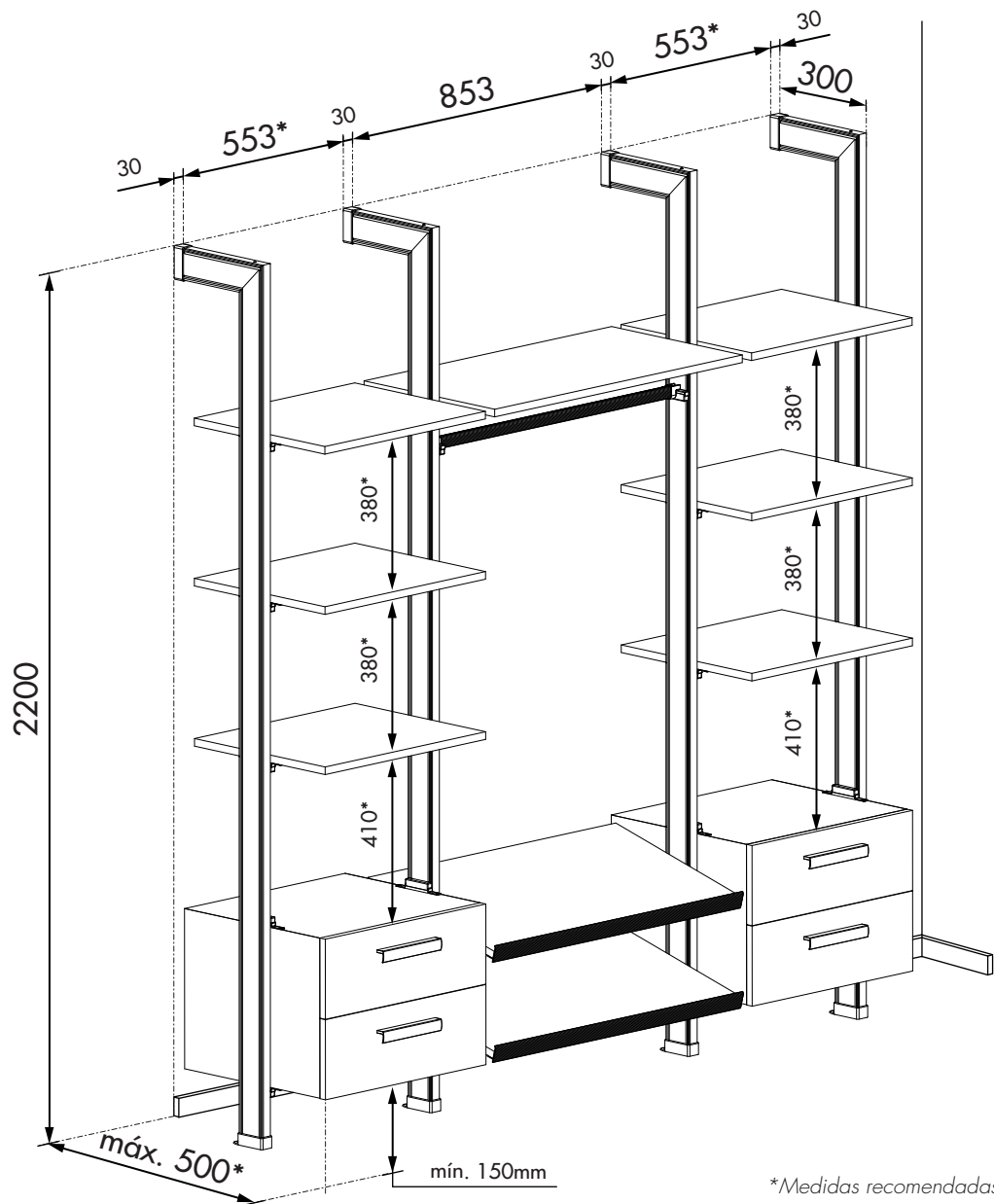
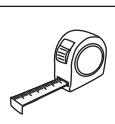

\*Medidas recomendadas

Unidades en milímetros | Units in millimeters | Unités en millimètres

A

2

ø5.5x25mm

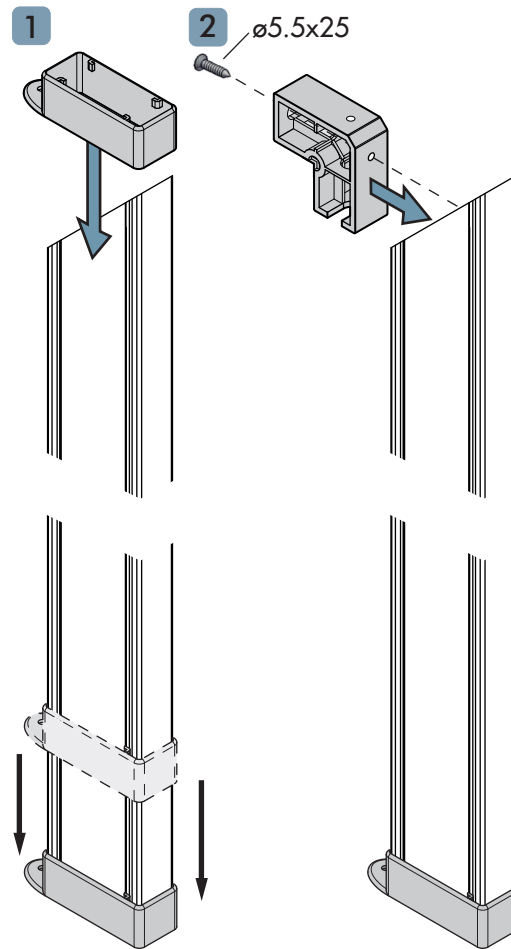
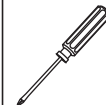

\*Tornillería recomendada

A

3

M6x40mm

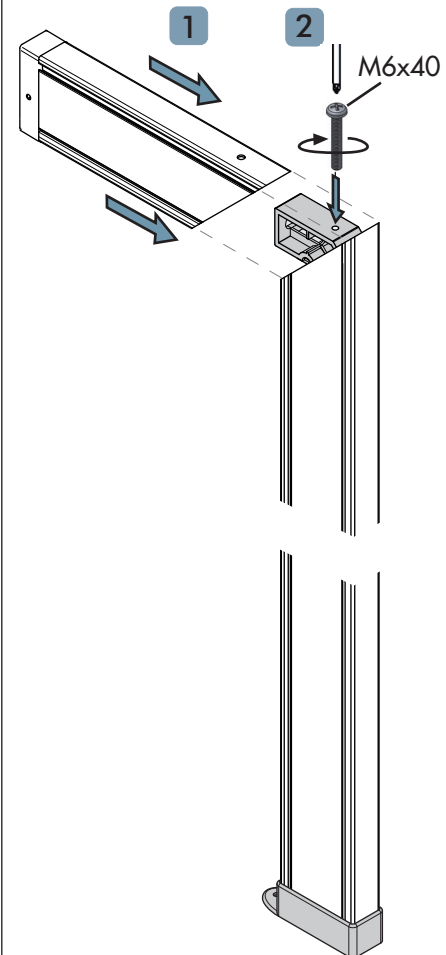
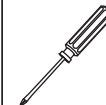

\*Tornillería recomendada

A

4

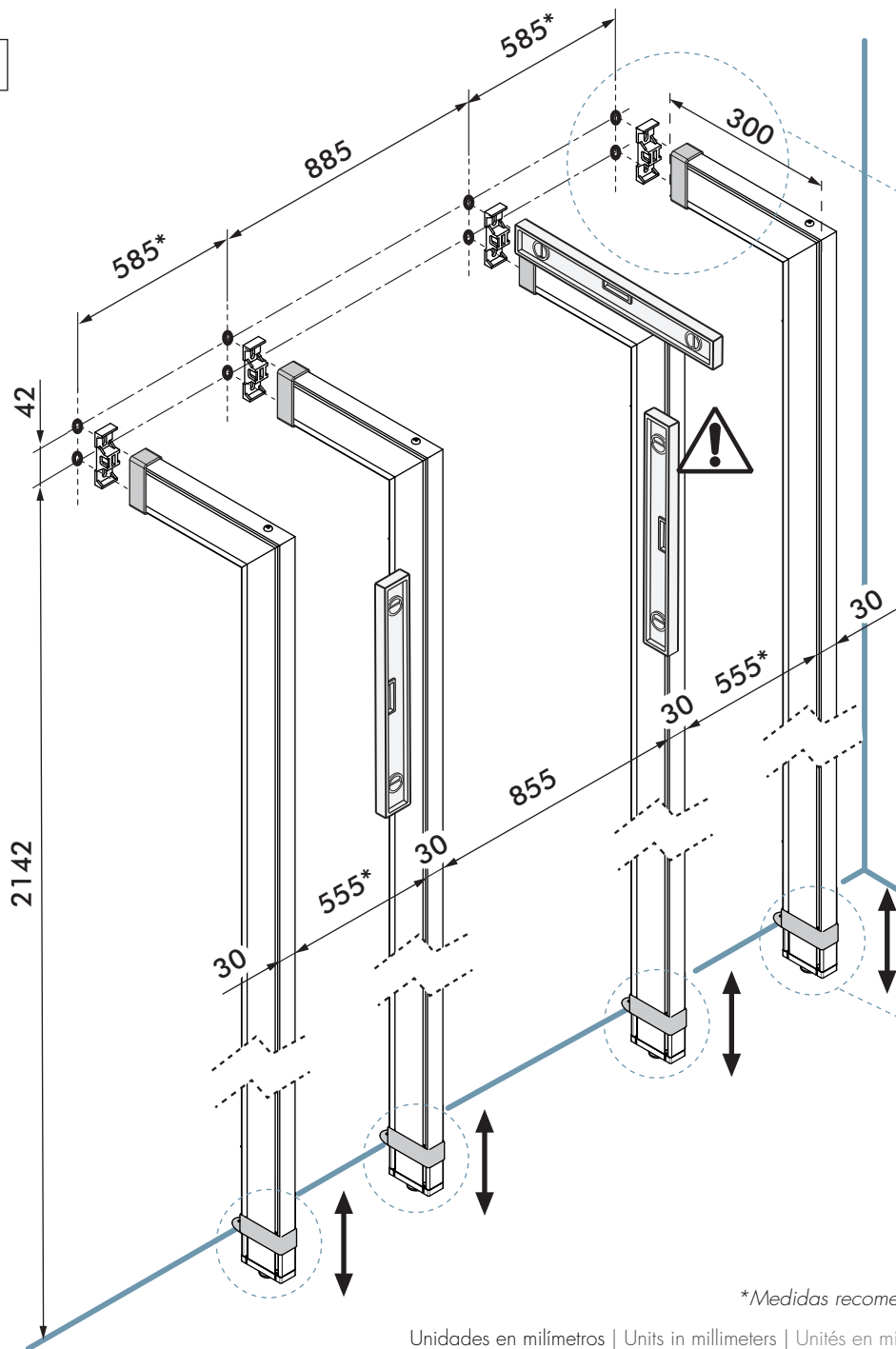

\*Medidas recomendadas

Unidades en milímetros | Units in millimeters | Unités en millimètres

A

5

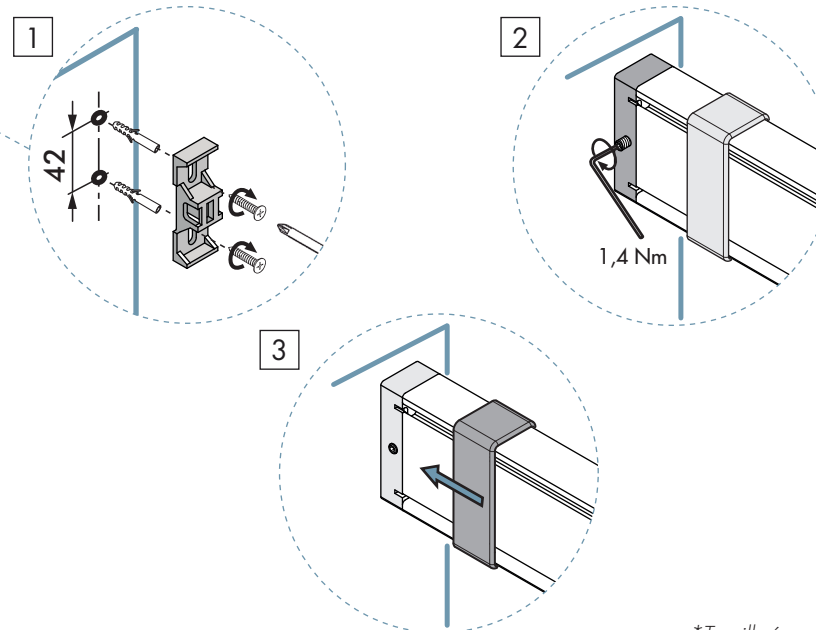
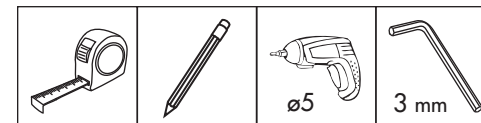

\*Tornillería recomendada

A

6

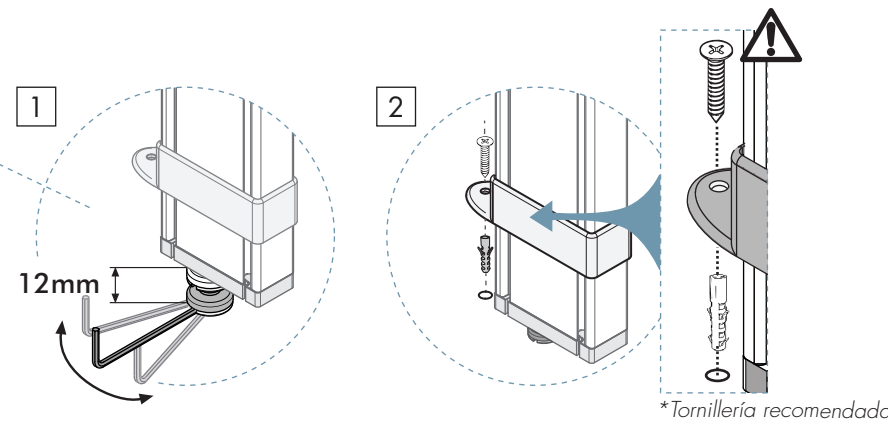
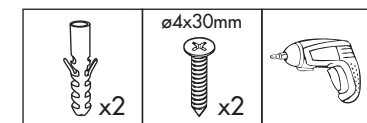

\*Tornillería recomendada

B C

1

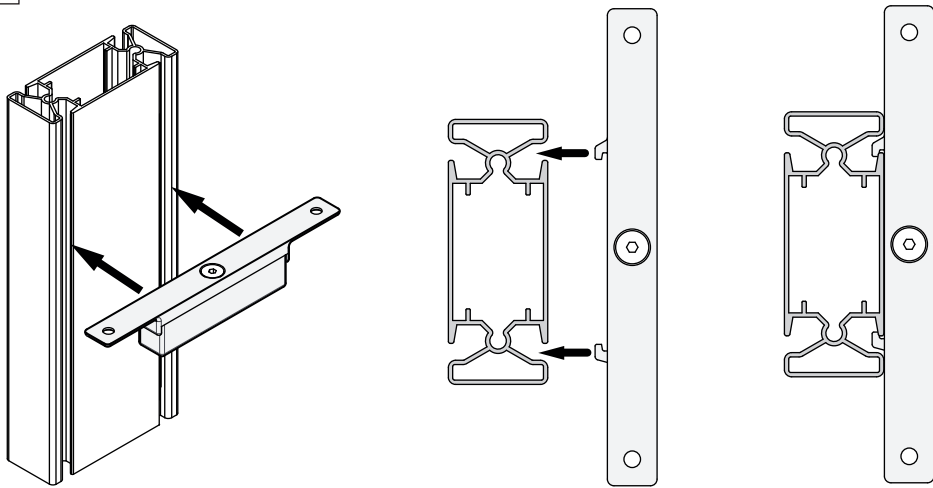

B C

2

Izquierda | Left | Gauche

Derecha | Right | Droit

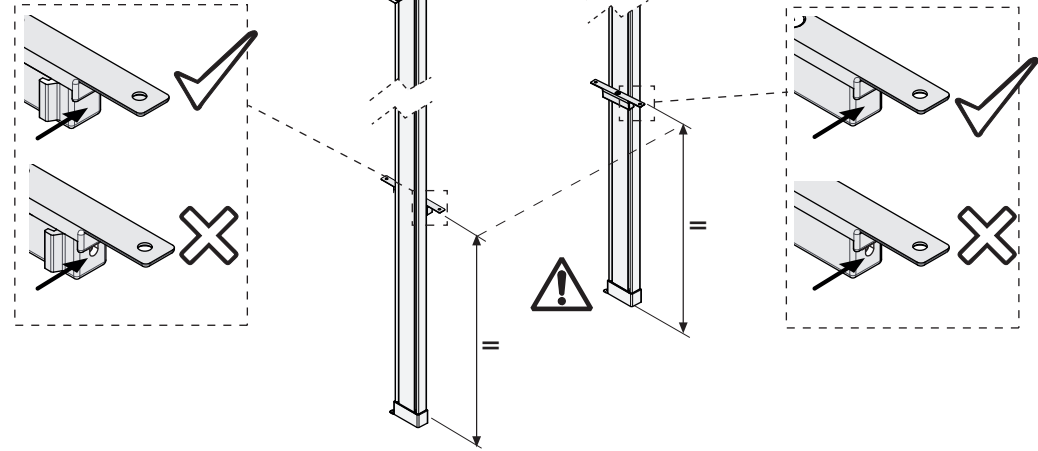

B C

3

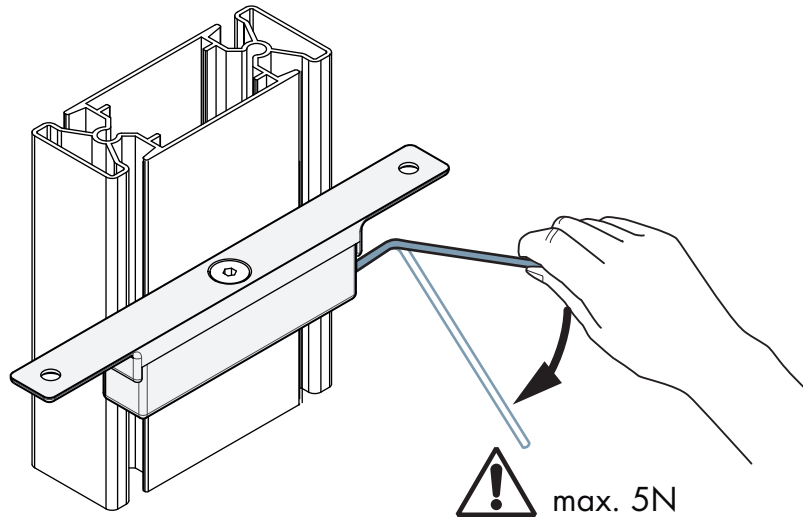
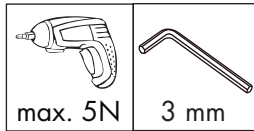

B C

4

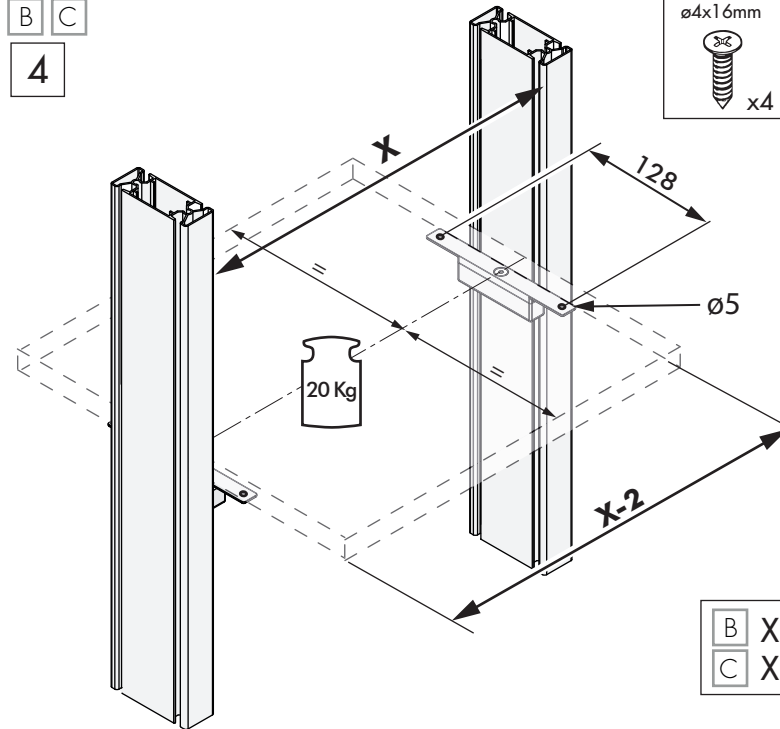
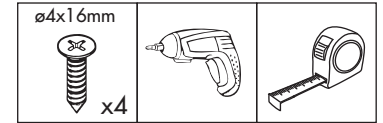

B	X = máx. 900 mm
C	X = 855

\*Tornillería recomendada

D

1

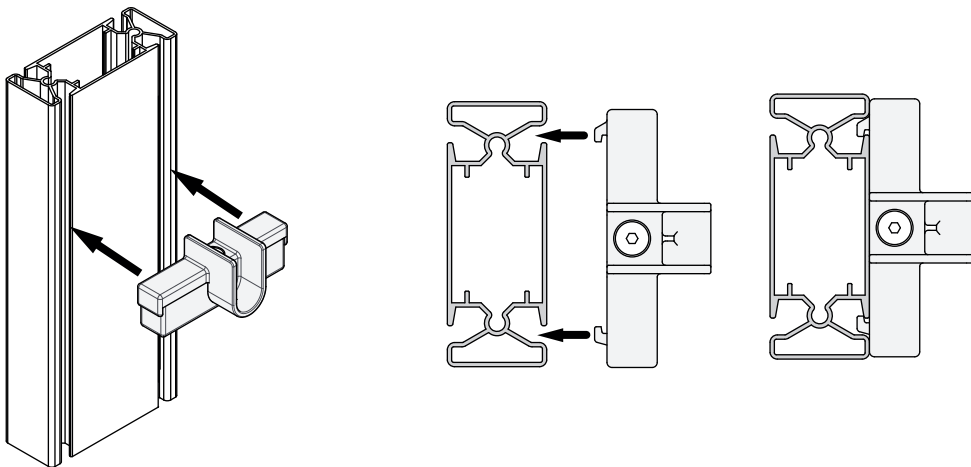

D

2

Izquierda | Left | Gauche

Derecha | Right | Droit

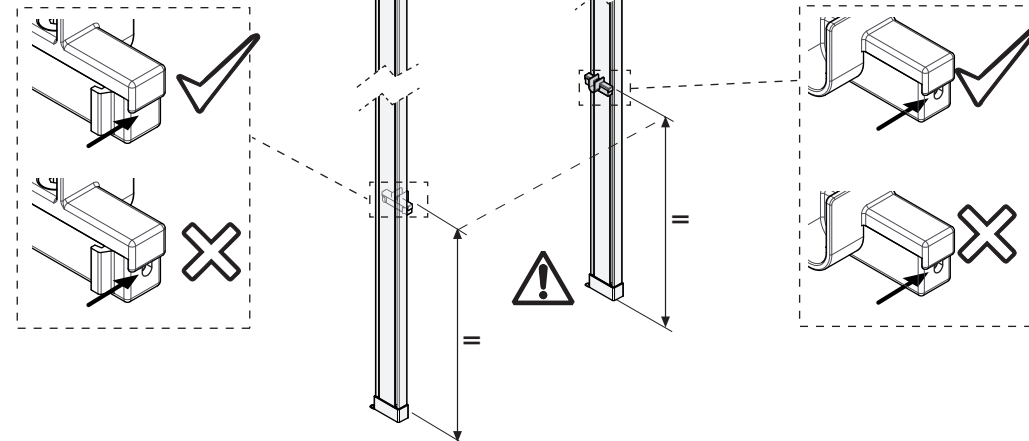

D

3

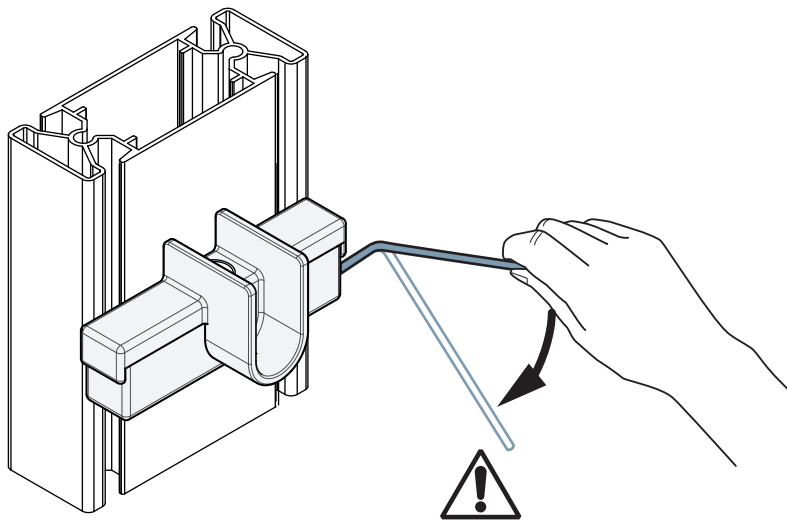
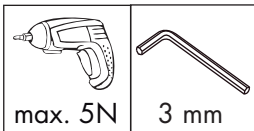

D

4

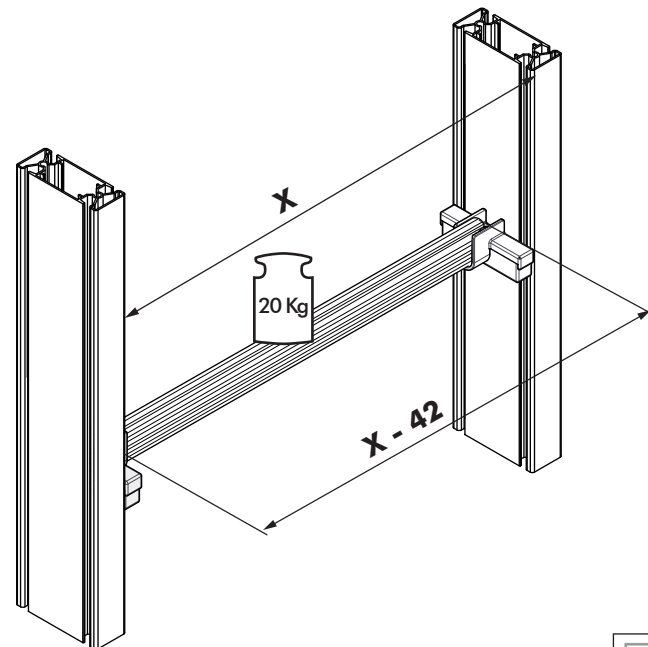

D X = 855 mm

E

1

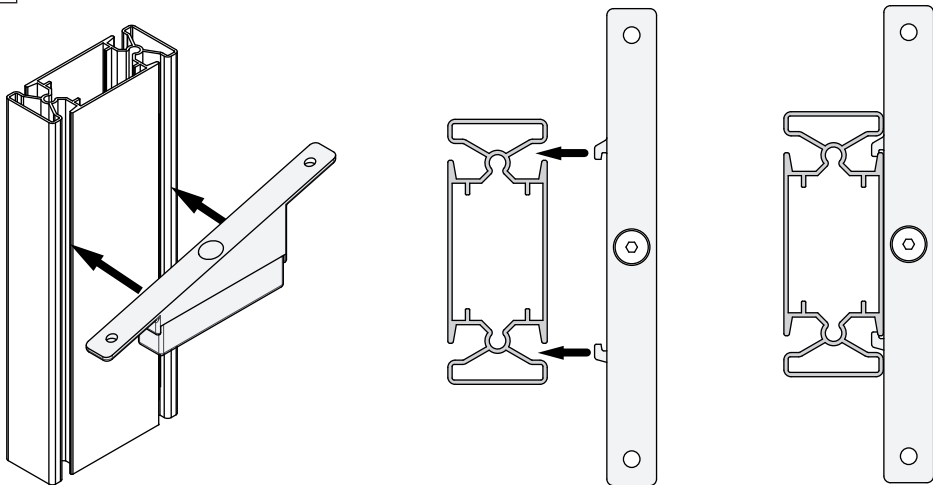

E

2

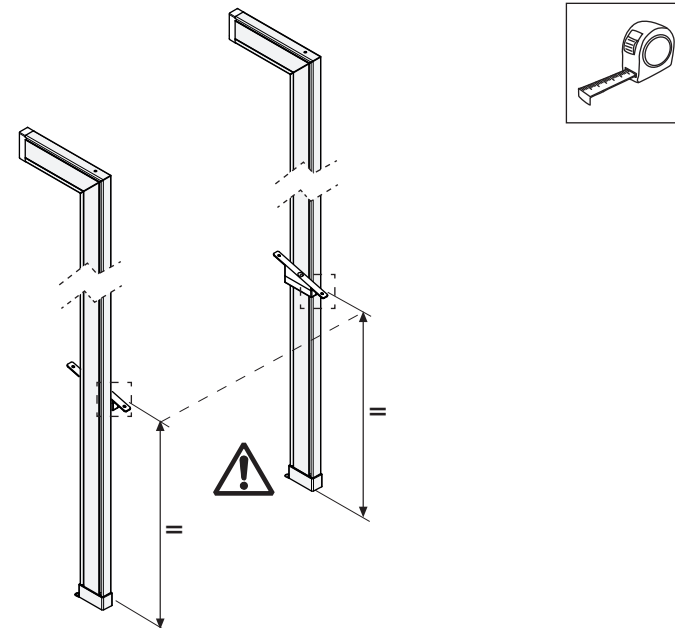

E

3

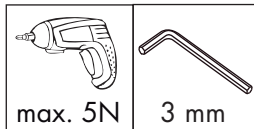

max. 5N 3 mm

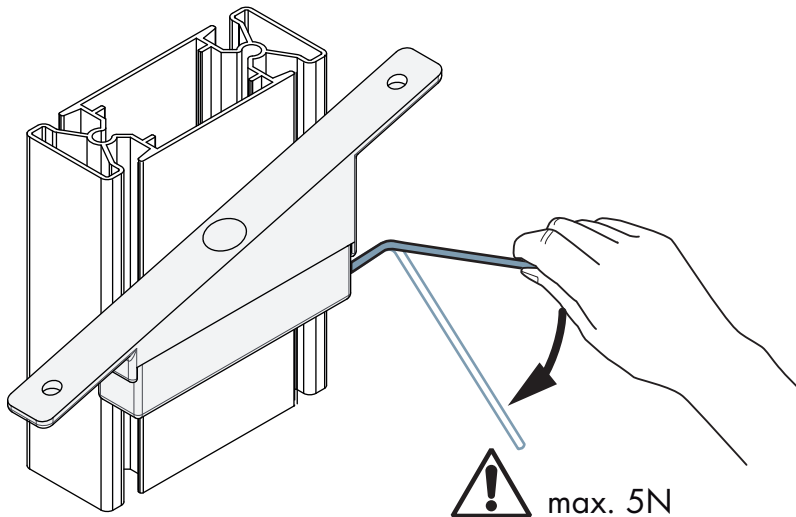

E

4

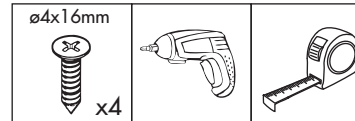

ø4x16mm x4

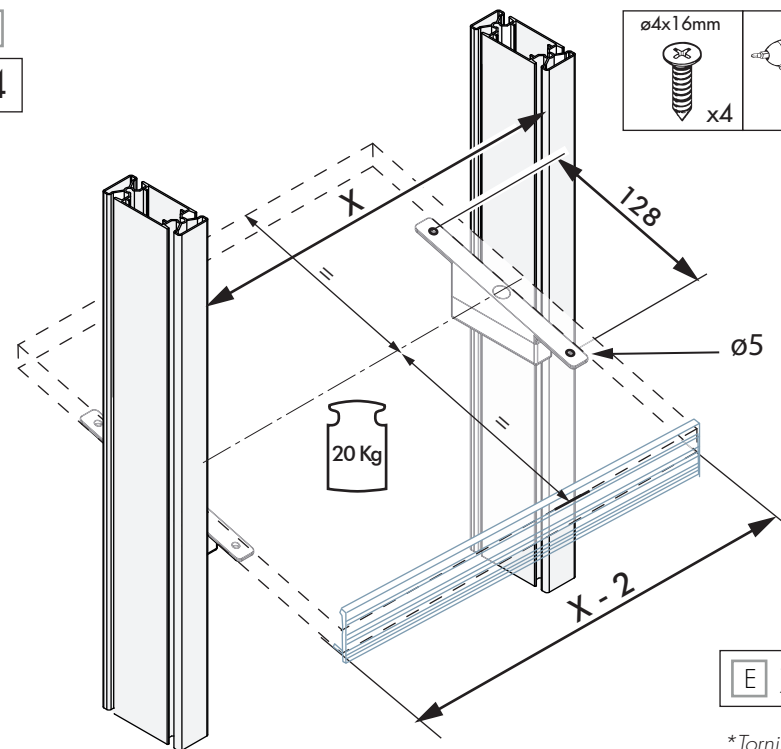

E X = 855 mm

\*Tornillería recomendada

F

1

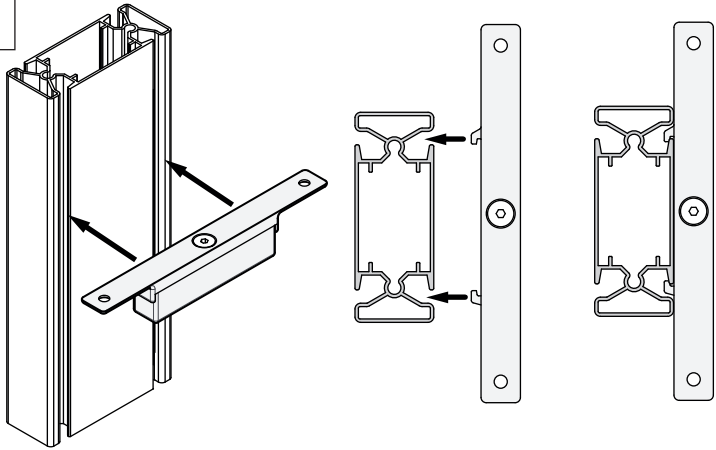

F

2

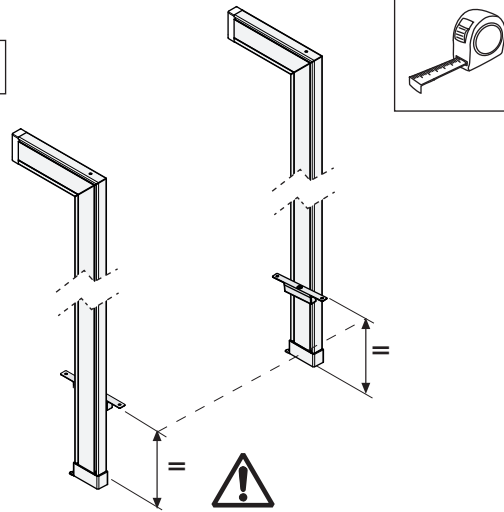

F

4

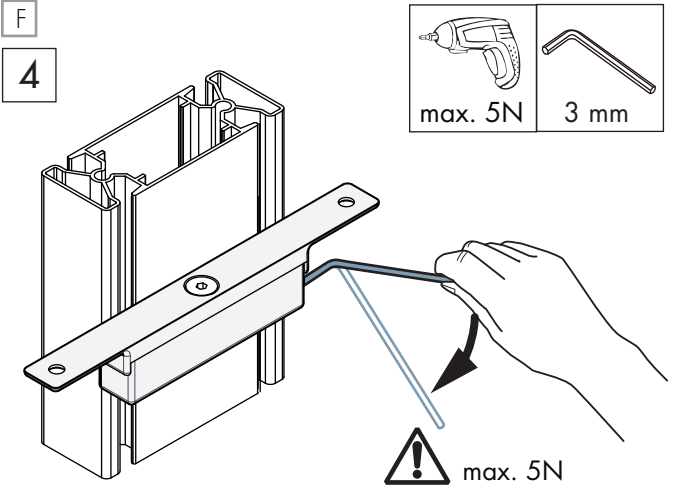

F

3

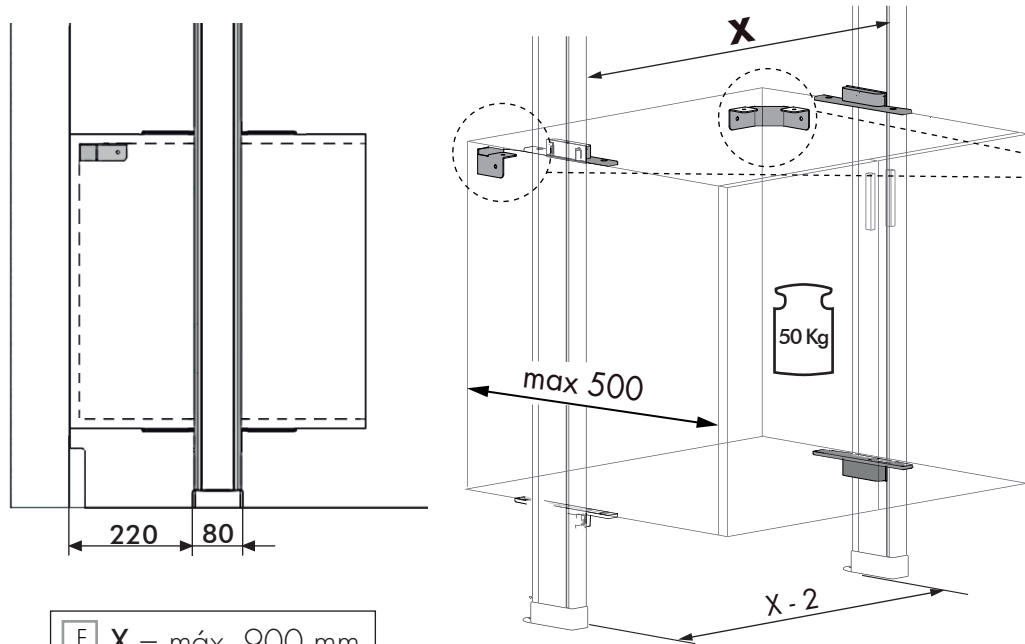
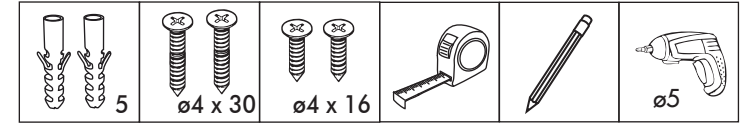

1

3

2

4

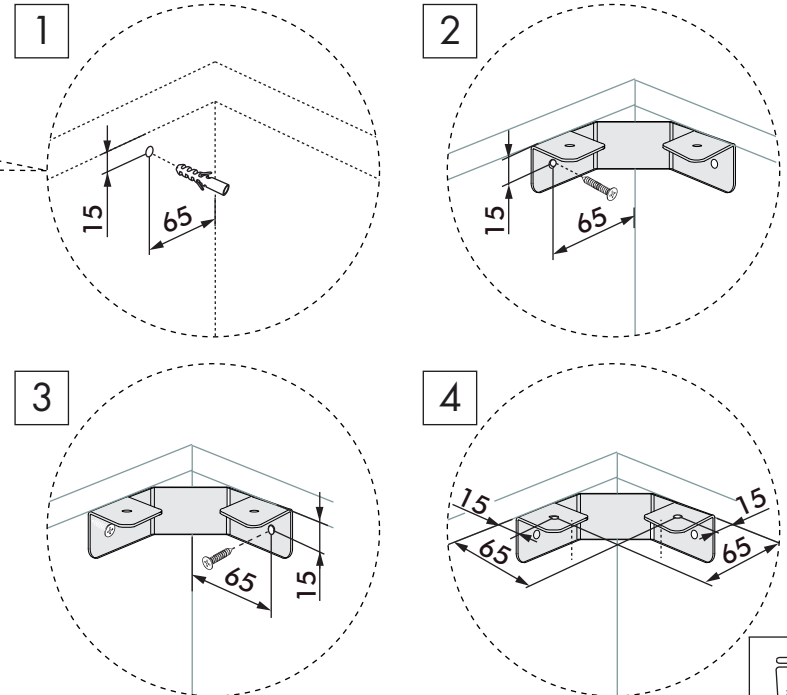

F X = máx. 900 mm

\*Tornillería recomendada

